



## Chapter 09

# Input-Output Devices

Computer Fundamentals - Pradeep K. Sinha & Priti Sinha

Computer Fundamentals: Pradeep K. Sinha & Priti Sinha

## Learning Objectives

**In this chapter you will learn about:**

- § Input/Output (I/O) devices
- § Commonly used input devices
- § Commonly used output devices
- § Other concepts related to I/O devices

## I/O Devices

- § Provide means of communication between a computer and outer world
- § Also known as peripheral devices because they surround the CPU and memory of a computer system
- § Input devices are used to enter data from the outside world into primary storage
- § Output devices supply results of processing from primary storage to users

## Role of I/O Devices

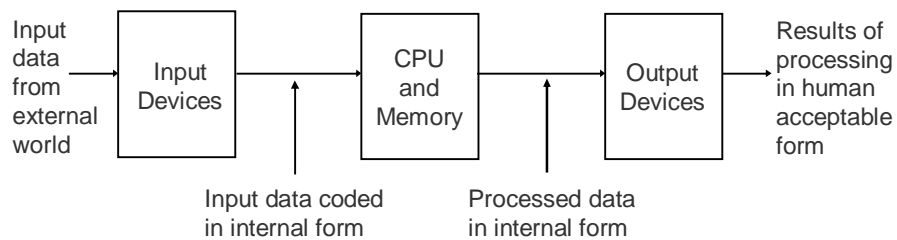

## Commonly Used Input Devices

- § Keyboard devices
- § Point-and-draw devices
- § Data scanning devices
- § Digitizer
- § Electronic cards based devices
- § Speech recognition devices
- § Vision based devices

## Keyboard Devices

- § Allow data entry into a computer system by pressing a set of keys (labeled buttons) neatly mounted on a keyboard connected to a computer system
- § 101-keys QWERTY keyboard is most popular

## The Layout of Keys on a QWERTY Keyboard

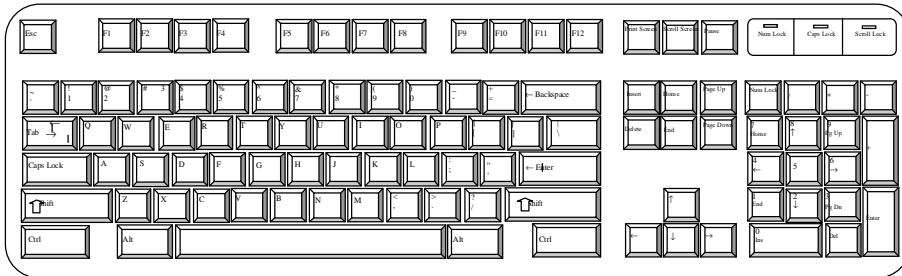

## Point-and-Draw Devices

- § Used to rapidly point to and select a graphic icon or menu item from multiple options displayed on the *Graphical User Interface (GUI)* of a screen
- § Used to create graphic elements on the screen such as lines, curves, and freehand shapes
- § Some commonly used point-and-draw devices are mouse, track ball, joy stick, light pen, and touch screen

# Mouse

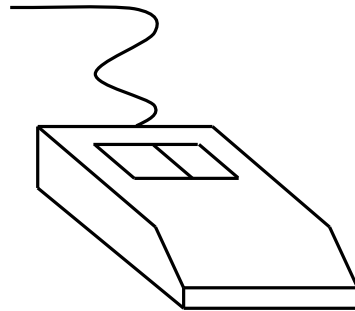

Commonly used in personal computers and workstations

# Trackball

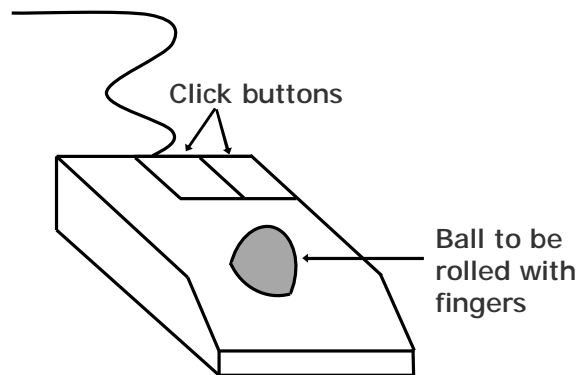

Commonly used in laptop (notebook) computers

## Joystick

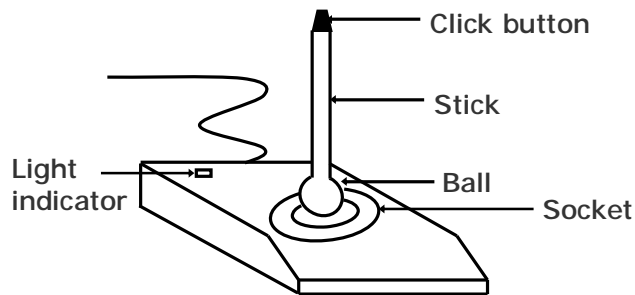

Commonly used for video games, flight simulators, training simulators, and for controlling industrial robots

## Electronic Pen

- § Pen-based point-and-draw device
- § Used to directly point with it on the screen to select menu items or icons or directly draw graphics on the screen
- § Can write with it on a special pad for direct input of written information to a system
- § Pressure on tip of a side button is used to cause same action as *right-button-click* of a mouse

## Touch Screen

- § Most simple, intuitive, and easiest to learn of all input devices
- § Enables users to choose from available options by simply touching with their finger the desired icon or menu item displayed on the screen
- § Most preferred human-computer interface used in *information kiosks* (unattended interactive information systems such as automatic teller machine or ATM)

## Data Scanning Devices

- § Input devices that enable direct data entry into a computer system from source documents
- § Eliminate the need to key in text data into the computer
- § Due to reduced human effort in data entry, they improve data accuracy and also increase the timeliness of the information processed
- § Demand high quality of input documents
- § Some data scanning devices are also capable of recognizing marks or characters
- § Form design and ink specification usually becomes more critical for accuracy

## Image Scanner

- § Input device that translates paper documents into an electronic format for storage in a computer
- § Electronic format of a scanned image is its bit map representation
- § Stored image can be altered or manipulated with an image-processing software

## Two Common Types of Image Scanners

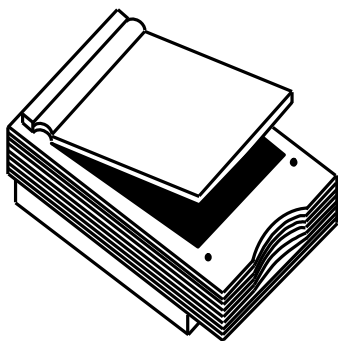

A flat-bed scanner

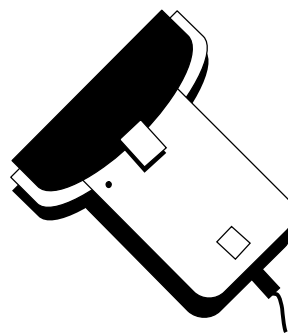

A hand-held scanner



## Optical Character Recognition (OCR) Device

- § Scanner equipped with a character recognition software (called OCR software) that converts the bit map images of characters to equivalent ASCII codes
- § Enables word processing of input text and also requires less storage for storing the document as text rather than an image
- § OCR software is extremely complex because it is difficult to make a computer recognize an unlimited number of typefaces and fonts
- § Two standard OCR fonts are OCR-A (American standard) and OCR-B (European standard)

## Optical Mark Reader (OMR)

- § Scanner capable of recognizing a pre-specified type of mark by pencil or pen
- § Very useful for grading tests with objective type questions, or for any input data that is of a choice or selection nature
- § Technique used for recognition of marks involves focusing a light on the page being scanned and detecting the reflected light pattern from the marks

## Sample Use of OMR

For each question, four options are given out of which only one is correct. Choose the correct option and mark your choice against the corresponding question number in the given answer sheet by darkening the corresponding circle with a lead pencil.

1. The binary equivalent of decimal 4 is:
  - a) 101
  - b) 111
  - c) 001
  - d) 100
2. The full form of CPU is:
  - a) Cursor Positioning Unit
  - b) Central Power Unit
  - c) Central Processing Unit
  - d) None of the above
3. Which is the largest unit of storage among the following:
  - a) Terabyte
  - b) Kilobyte
  - c) Megabyte
  - d) Gigabyte

Indicates direction in which the sheet should be fed to the OMR

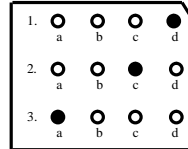

(b) Pre-printed answer sheet

(a) Question sheet

A sample use of OMR for grading tests with objective type questions

## Bar-code Reader

- § Scanner used for reading (decoding) bar-coded data
- § Bar codes represent alphanumeric data by a combination of adjacent vertical lines (bars) by varying their width and the spacing between them
- § Scanner uses laser-beam to stroke across pattern of bar code. Different patterns of bars reflect the beam in different ways sensed by a light-sensitive detector
- § Universal Product Code (UPC) is the most widely known bar coding system

## An Example of UPC Bar Code

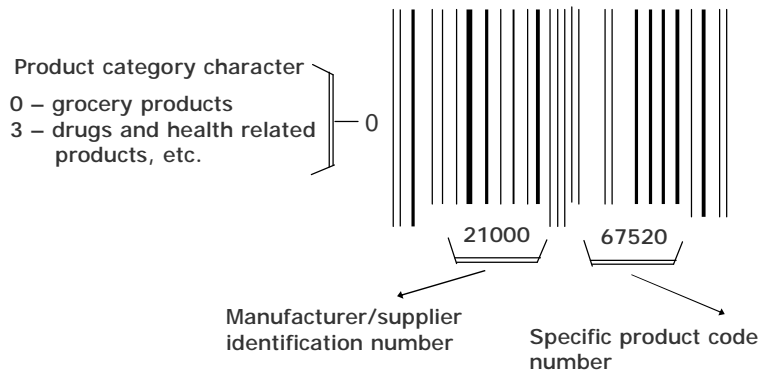

## Magnetic-Ink Character Recognition (MICR)

- § MICR is used by banking industry for faster processing of large volume of cheques
- § Bank's identification code (name, branch, etc.), account number and cheque number are pre-printed (encoded) using characters from a special character set on all cheques
- § Special ink is used that contains magnetizable particles of iron oxide
- § MICR reader-sorter reads data on cheques and sorts them for distribution to other banks or for further processing

## MICR Character Set (E13B Font)

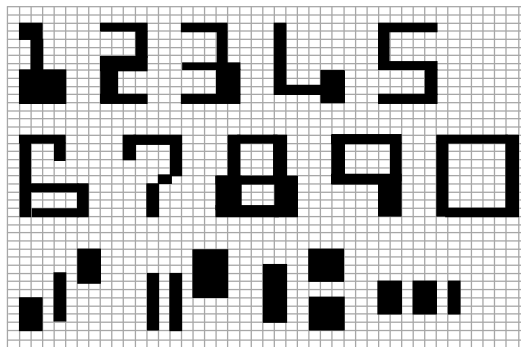

- § It consists of numerals 0 to 9 and four special characters
- § MICR is not adopted by other industries because it supports only 14 symbols

## Digitizer

- § Input device used for converting (digitizing) pictures, maps and drawings into digital form for storage in computers
- § Commonly used in the area of Computer Aided Design (CAD) by architects and engineers to design cars, buildings medical devices, robots, mechanical parts, etc.
- § Used in the area of Geographical Information System (GIS) for digitizing maps available in paper form

## A Digitizer

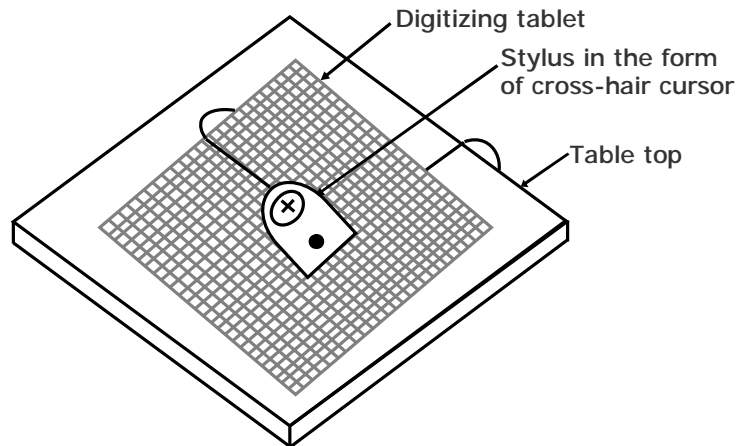

## Electronic-card Reader

- § Electronic cards are small plastic cards having encoded data appropriate for the application for which they are used
- § Electronic-card reader (normally connected to a computer) is used to read data encoded on an electronic card and transfer it to the computer for further processing
- § Used together as a means of direct data entry into a computer system
- § Used by banks for use in automatic teller machines (ATMs) and by organizations for controlling access of employees to physically secured areas

## Speech Recognition Devices

- § Input device that allows a person to input data to a computer system by speaking to it
- § Today's speech recognition systems are limited to accepting few words within a relatively small domain and can be used to enter only limited kinds and quantities of data

## Types of Speech Recognition Systems

(Continued from previous slide..)

- § *Single word recognition systems* can recognize only a single spoken words, such as YES, NO, MOVE, STOP, at a time. Speaker-independent systems are mostly of this type
- § *Continuous speech recognition systems* can recognize spoken sentences, such as MOVE TO THE NEXT BLOCK. Such systems are normally speaker-dependent

## Uses of Speech Recognition Systems

- § For inputting data to a computer system by a person in situations where his/her hands are busy, or his/her eyes must be fixed on a measuring instrument or some other object
- § For data input by dictation of long text or passage for later editing and review
- § For authentication of a user by a computer system based on voice input
- § For limited use of computers by individuals with physical disabilities

## Vision-Input Systems

- § Allow computer to accept input just by seeing an object.
- § Input data is normally an object's shape and features in the form of an image
- § Mainly used today in factories for designing industrial robots that are used for quality-control and assembly processes

## Commonly Used Output Devices

- § Monitors
- § Printers
- § Plotters
- § Screen image projector
- § Voice response systems

## Types of Output

- § **Soft-copy output**
  - § Not produced on a paper or some material that can be touched and carried for being shown to others
  - § Temporary in nature and vanish after use
  - § Examples are output displayed on a terminal screen or spoken out by a voice response system
- § **Hard-copy output**
  - § Produced on a paper or some material that can be touched and carried for being shown to others
  - § Permanent in nature and can be kept in paper files or can be looked at a later time when the person is not using the computer
  - § Examples are output produced by printers or plotters on paper



## Monitors

- § Monitors are the most popular output devices used for producing soft-copy output
- § Display the output on a television like screen
- § Monitor associated with a keyboard is called a video display terminal (VDT). It is the most popular I/O device

## Monitors

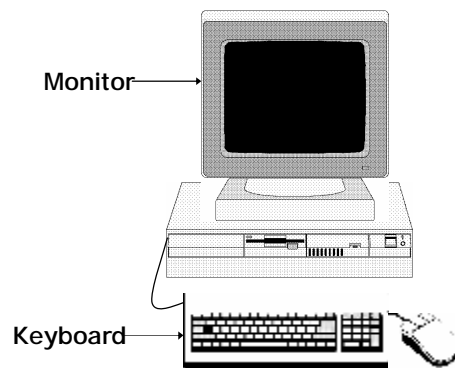

A video display terminal consists of a monitor and a keyboard

## Types of Monitors

- § Cathode-ray-tube (CRT) monitors look like a television and are normally used with non-portable computer systems
- § Flat-panel monitors are thinner and lighter and are commonly used with portable computer systems like notebook computers. Now they are also used with non-portable desktop computer systems because they occupy less table space.

## Printers

Most common output devices for producing hard-copy output

## Dot-Matrix Printers

- § Character printers that form characters and all kinds of images as a pattern of dots
- § Print many special characters, different sizes of print and graphics such as charts and graphs
- § Impact printers can be used for generating multiple copies by using carbon paper or its equivalent
- § Slow, with speeds usually ranging between 30 to 600 characters per second
- § Cheap in both initial cost and cost of operation

## Formation of Characters as a pattern of dots

ABCDEFGHIJKLMNO  
PQRSTUVWXYZ  
0123456789-.,  
&/\$\*#% @=(+)

## A Dot Matrix Printer

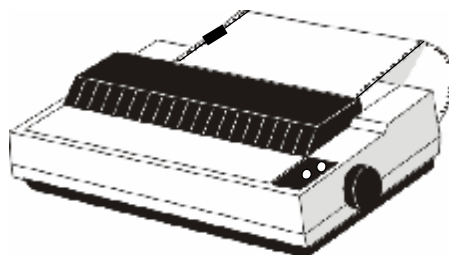

## Inkjet Printers

- § Character printers that form characters and all kinds of images by spraying small drops of ink on to the paper
- § Print head contains up to 64 tiny nozzles that can be selectively heated up in a few micro seconds by an integrated circuit register
- § To print a character, the printer selectively heats the appropriate set of nozzles as the print head moves horizontally
- § Can print many special characters, different sizes of print, and graphics such as charts and graphs

*(Continued on next slide)*

## Inkjet Printers

(Continued from previous slide..)

- § Non-impact printers. Hence, they cannot produce multiple copies of a document in a single printing
- § Can be both monochrome and color
- § Slower than dot-matrix printers with speeds usually ranging between 40 to 300 characters per second
- § More expensive than a dot-matrix printer

## An Inkjet Printers

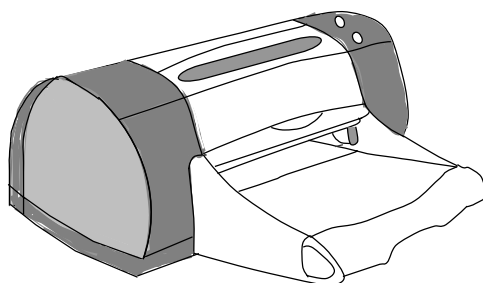

# Drum Printers

- § Line printers that print one line at a time
- § Have a solid cylindrical drum with characters embossed on its surface in the form of circular bands
- § Set of hammers mounted in front of the drum in such a manner that an inked ribbon and paper can be placed between the hammers and the drum
- § Can only print a pre-defined set of characters in a pre-defined style that is embossed on the drum
- § Impact printers and usually monochrome
- § Typical speeds are in the range of 300 to 2000 lines per minute

# Printing Mechanism of a Drum Printer

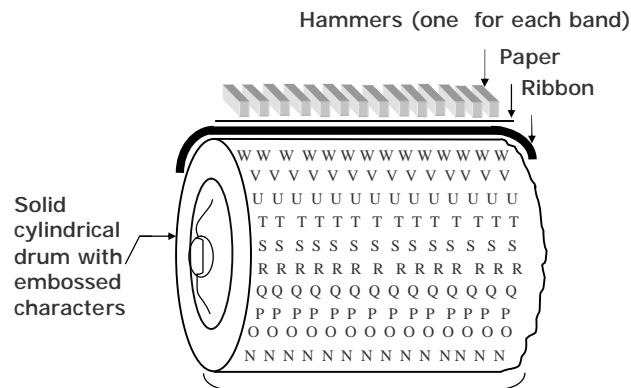

Total number of bands is equal to the maximum number of characters (print positions) on a line

## Chain/Band Printers

- § Line printers that print one line at a time
- § Consist of a metallic chain/band on which all characters of the character set supported by the printer are embossed
- § Also have a set of hammers mounted in front of the chain/band in such a manner that an inked ribbon and paper can be placed between the hammers and the chain/band

## Chain/Band Printers

- § Can only print pre-defined sets of characters that are embossed on the chain/band used with the printer
- § Cannot print any shape of characters, different sizes of print, and graphics such as charts and graphs
- § Are impact printers and can be used for generating multiple copies by using carbon paper or its equivalent
- § Are usually monochrome
- § Typical speeds are in the range of 400 to 3000 lines per minute

## Laser Printers

- § Page printers that print one page at a time
- § Consist of a laser beam source, a multi-sided mirror, a photoconductive drum and toner (tiny particles of oppositely charged ink)
- § To print a page, the laser beam is focused on the electro statically charged drum by the spinning multi-sided mirror
- § Toner sticks to the drum in the places the laser beam has charged the drum's surface.
- § Toner is then permanently fused on the paper with heat and pressure to generate the printer output
- § Laser printers produce very high quality output having resolutions in the range of 600 to 1200 dpi

*(Continued on next slide)*

## Laser Printers

*(Continued from previous slide..)*

- § Can print many special characters, different sizes of print, and graphics such as charts and graphs
- § Are non-impact printers
- § Most laser printers are monochrome, but color laser printers are also available
- § Low speed laser printers can print 4 to 12 pages per minute. Very high-speed laser printers can print 500 to 1000 pages per minute
- § More expensive than other printers



## A Laser Printers

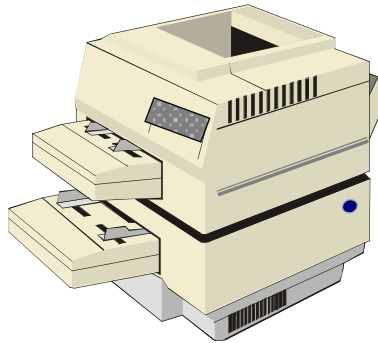

## Plotters

- § Plotters are an ideal output device for architects, engineers, city planners, and others who need to routinely generate high-precision, hard-copy graphic output of widely varying sizes
- § Two commonly used types of plotters are:
  - *Drum plotter*, in which the paper on which the design has to be made is placed over a drum that can rotate in both clockwise and anti-clockwise directions
  - *Flatbed plotter*, in which the paper on which the design has to be made is spread and fixed over a rectangular flatbed table

## A Drum Plotter

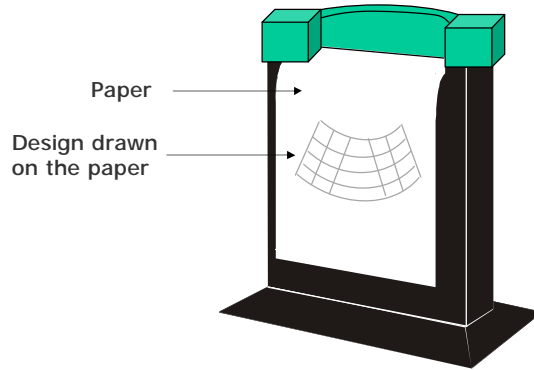

## A Flatbed Plotter

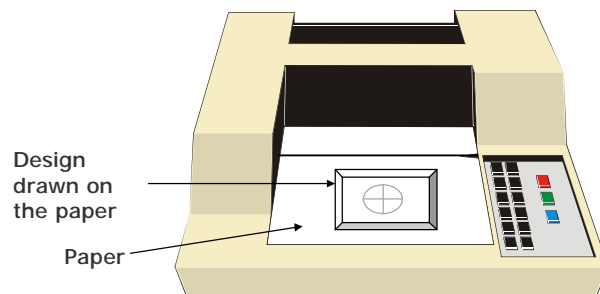

## Screen Image Projector

- § An output device that can be directly plugged to a computer system for projecting information from a computer on to a large screen
- § Useful for making presentations to a group of people with direct use of a computer
- § Full-fledged multimedia presentation with audio, video, image, and animation can be prepared and made using this facility

## Voice Response Systems

- § Voice response system enables a computer to talk to a user
- § Has an audio-response device that produces audio output
- § Such systems are of two types:
  - § Voice reproduction systems
  - § Speech synthesizers

*(Continued on next slide)*

## Voice Reproduction Systems

(Continued from previous slide..)

- § Produce audio output by selecting an appropriate audio output from a set of pre-recorded audio responses
- § Applications include audio help for guiding how to operate a system, automatic answering machines, video games, etc.

## Speech Synthesizers

- § Converts text information into spoken sentences
- § Used for applications such as:
  - § Reading out text information to blind persons
  - § Allowing those persons who cannot speak to communicate effectively
  - § Translating an entered text into spoken words in a selected language

## Key Words/Phrases

- § Bard code reader
- § Cathode Ray Tube (CRT)
- § Chain/Band printer
- § Data scanning device
- § Digitizer
- § Digitizing tablet
- § Dot-Matrix printer
- § Drum plotter
- § Drum printer
- § Electronic card reader
- § Electronic Pen
- § Flatbed plotter
- § Flatbed Scanner
- § Graphical User Interface
- § Hand-held scanner
- § Hard-copy output
- § Image Scanner
- § Information Kiosk
- § Inkjet printer
- § Input/Output device
- § Joystick
- § Keyboard device
- § Laser printer
- § Magnetic-Ink Character Recognition (MICR)
- § Monitor
- § Mouse
- § Optical Character Recognition (OCR)
- § Optical Mark Reader (OMR)
- § Peripheral device
- § Phonemes
- § Plotter
- § Point-and-draw device
- § Printer
- § QWERTY keyboard
- § Screen Image Projector

(Continued on next slide)

## Key Words/Phrases

(Continued from previous slide..)

- § Soft-copy output
- § Speech synthesizer
- § Stylus
- § Touch Screen
- § Trackball
- § Universal Product Code (UPC)
- § Video Display Terminal (VDT)
- § Vision-input system
- § Voice recognition device
- § Voice reproduction system
- § Voice response system