

Chapter 02

Basic Computer Organization

Computer Fundamentals - Pradeep K. Sinha & Priti Sinha

Computer Fundamentals: Pradeep K. Sinha & Priti Sinha

Learning Objectives

In this chapter you will learn about:

- § Basic operations performed by all types of computer systems
- § Basic organization of a computer system
- § Input unit and its functions
- § Output unit and its functions
- § Storage unit and its functions
- § Types of storage used in a computer system

(Continued on next slide)

Learning Objectives

(Continued from previous slide..)

- § Arithmetic Logic Unit (ALU)
- § Control Unit (CU)
- § Central Processing Unit (CPU)
- § Computer as a system

The Five Basic Operations of a Computer System

- § **Inputting.** The process of entering data and instructions into the computer system
- § **Storing.** Saving data and instructions to make them readily available for initial or additional processing whenever required
- § **Processing.** Performing arithmetic operations (add, subtract, multiply, divide, etc.) or logical operations (comparisons like equal to, less than, greater than, etc.) on data to convert them into useful information

(Continued on next slide)

The Five Basic Operations of a Computer System

- § **Outputting.** The process of producing useful information or results for the user such as a printed report or visual display

- § **Controlling.** Directing the manner and sequence in which all of the above operations are performed

Basic Organization of a Computer System

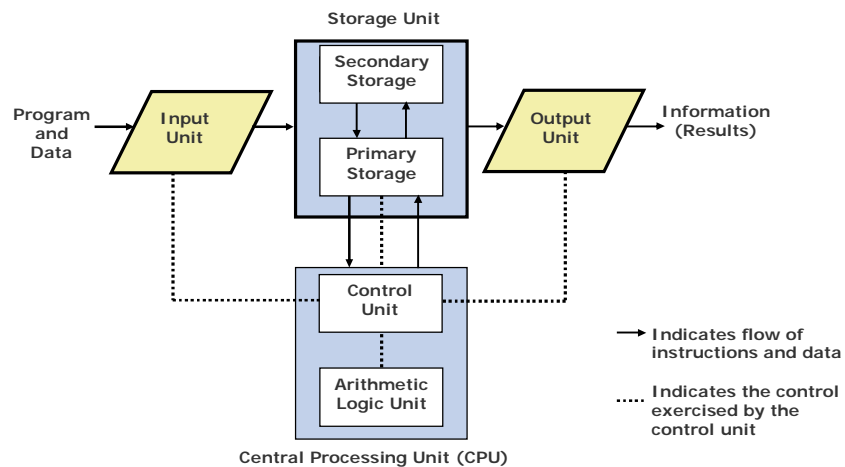

Input Unit

An input unit of a computer system performs the following functions:

1. It accepts (or reads) instructions and data from outside world
2. It converts these instructions and data in computer acceptable form
3. It supplies the converted instructions and data to the computer system for further processing

Output Unit

An output unit of a computer system performs the following functions:

1. It accepts the results produced by the computer, which are in coded form and hence, cannot be easily understood by us
2. It converts these coded results to human acceptable (readable) form
3. It supplies the converted results to outside world

Storage Unit

The storage unit of a computer system holds (or stores) the following :

1. Data and instructions required for processing (received from input devices)
2. Intermediate results of processing
3. Final results of processing, before they are released to an output device

Two Types of Storage

§ Primary storage

- § Used to hold running program instructions
- § Used to hold data, intermediate results, and results of ongoing processing of job(s)
- § Fast in operation
- § Small Capacity
- § Expensive
- § Volatile (loses data on power dissipation)

(Continued on next slide)

Two Types of Storage

(Continued from previous slide..)

§ Secondary storage

- § Used to hold stored program instructions
- § Used to hold data and information of stored jobs
- § Slower than primary storage
- § Large Capacity
- § Lot cheaper that primary storage
- § Retains data even without power

Arithmetic Logic Unit (ALU)

Arithmetic Logic Unit of a computer system is the place where the actual executions of instructions takes place during processing operation

Control Unit (CU)

Control Unit of a computer system manages and coordinates the operations of all other components of the computer system

Central Processing Unit (CPU)

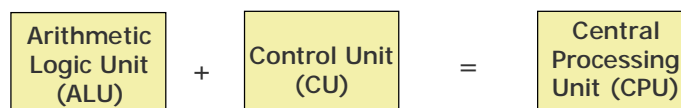

- § It is the brain of a computer system
- § It is responsible for controlling the operations of all other units of a computer system

The System Concept

A system has following three characteristics:

1. A system has more than one element
2. All elements of a system are logically related
3. All elements of a system are controlled in a manner to achieve the system goal

A computer is a system as it comprises of integrated components (input unit, output unit, storage unit, and CPU) that work together to perform the steps called for in the executing program

Key Words/Phrases

- | | |
|---------------------------------|---------------------|
| § Arithmetic Logic Unit (ALU) | § Output interface |
| § Auxiliary storage | § Output unit |
| § Central Processing Unit (CPU) | § Outputting |
| § Computer system | § Primate storage |
| § Control Unit (CU) | § Processing |
| § Controlling | § Secondary storage |
| § Input interface | § Storage unit |
| § Input unit | § Storing |
| § Inputting | § System |
| § Main memory | |